



Agilent U1083A-007

Acqiris SVM4800 High-Speed 6U
VME/VXS Digitizer

14-bit, 8 ch, 300 MHz, 125 MS/s



Agilent Technologies



Main Features

- 6U single slot VME/VXS (VITA 41)
- Eight-channel, 14-bit, 125 MS/s ADC
- External clock
- One Xilinx Virtex-5 FPGA for static data correction and multiplexing
- Two Xilinx Virtex-4 FPGAs for real-time signal processing and data flow control
- Two on-board DDR2 SDRAM banks, 32 Mwords, each 64-bit wide, for a total of 512 MB
- Tundra TSI148 VME bus interface, VME64x and 2eSST compliant
- VXS VITA 41.0 compliant, 8x 3.125 Gbps serial I/O links on P0 connector
- Two front panel SFP slots for up to 3.125 Gbps fiber or copper transceivers
- Auxiliary I/O mezzanine with multipurpose 12-bit 65 MS/s ADC, 12-bit 130 MS/s DAC, and 14 digital I/O ports on front panel
- External trigger input
- High-speed digital I/O on P0 and P2 user-defined I/O
- Firmware Development Kit containing FPGA interface cores, software, and reference design
- FPGA-based VXS and optical data link interfaces for easier adaptation to different protocols
- Local FLASH memory able to store multiple FPGA bitstreams for complex, multimode applications
- Device drivers for Windows®, VxWorks®, and Linux®

High-Resolution, High-Sample-Rate Data Conversion with Real-Time Processing

The Agilent Acqiris SVM4800 is based on a modular VME/VXS platform common to all U1083A family products and features an eight-channel, 14-bit, 125 MS/s ADC coupled with a processing engine capable of up to 300 GigaMAC/s.

The U1083A board family features two Xilinx Virtex-4 FPGAs, one SX55 targeted at digital signal processing, and one FX100 for data flow control. The embedded 128 MB FLASH memory allows the platform to be easily reconfigured to perform user defined applications.

This architecture makes the new platform ideal for wide-band, high-dynamic-range, demanding applications such as electronic warfare (EW), radar digital receiver, telecommunications, and semiconductor testing, where high resolution, high sample rate, high data-processing capabilities, and high throughput are mandatory.

The SVM4800 module provides an analog mezzanine, based on two DC coupled quad-channel, 14-bit, 125 MS/s Texas Instruments ADS6445 ADCs, and supports its full capabilities and performance. The module works in external clock only, enabling optimized analog performance. The mezzanine also features a Xilinx Virtex-5 SX50T FPGA providing data MUX and static offset and gain correction by the mean of a digital multiplier/adder.

The board supports eight 3.125 Gbps serial links on the VXS backplane and two optical links on the front panel supporting up to 3.125 Gbps, providing a substantial aggregate data bandwidth of more than 3.5 GB/s. It also includes a fully compliant VME64x interface supporting the 2eSST protocol. A comprehensive Firmware Development Kit (FDK), software drivers, and application examples make it easier to develop your applications.

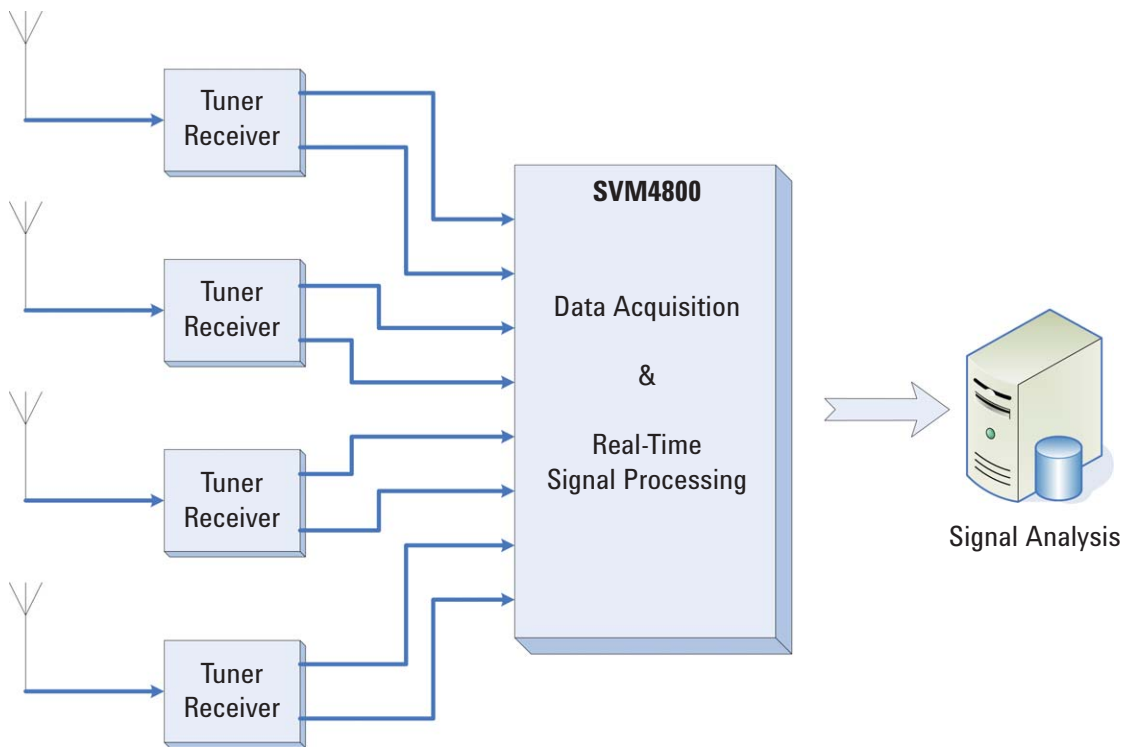

Figure 1 : Block diagram of an SVM4800 application example.

Extended Functionality

Trigger

The external trigger circuitry includes a switchable 50 Ω /1 M Ω front end coupled with a very-high-speed comparator chip and a 12-bit DAC for threshold adjustment.

Processing clock distribution

The COS201, a sophisticated proprietary clock distribution circuit, is used to synchronize all internal resources and allows fine control of processing and I/O synchronization.

Analog mezzanines

The SVM4800 features an eight channel 14-bit, 125 MS/s ADC mezzanine based on two Texas Instruments ADS6445 ADCs with a DC-coupled analog front end.

External clock input

The SVM4800 works in external clock mode. The clock is distributed through the mezzanine by Analog Devices AD9514, a very low jitter added clock distribution circuit.

Data correction and multiplexer

The mezzanine also includes a Xilinx Virtex-5 SX50T FPGA, provided to multiplex the data and correct static offset and gain errors.

JTAG

The SVM4800 features a JTAG connector that can be used for on board firmware debug using a ChipScope probe (requires option U1091A-CB1).

Auxiliary I/O mezzanine

The SVM4800 features an auxiliary I/O mezzanine to support control and command functions. It includes one 12-bit 65 MS/s ADC, one 12-bit 130 MS/s DAC, and 14 digital I/Os.

On-board processing FPGA

The SVM4800 offers on-board, high-performance, real-time data processing by means of two very large FPGAs, one Xilinx Virtex-4 SX55 and one Xilinx Virtex-4 FX100. The SX55 FPGA is capable of executing 512 multiplications / accumulations (18x18) at up to 450 MHz, leading to an impressive processing power of 230 GigaMAC/s, while offering more than 55,000 logic cells and up to 5 Mbits of on-chip RAM.

Optical data links

Two SFP front-panel optical transceivers provide for data transfer at rates of up to 3.125 Gbps per link. The link layer implemented by the provided firmware is based on Xilinx Aurora protocol.

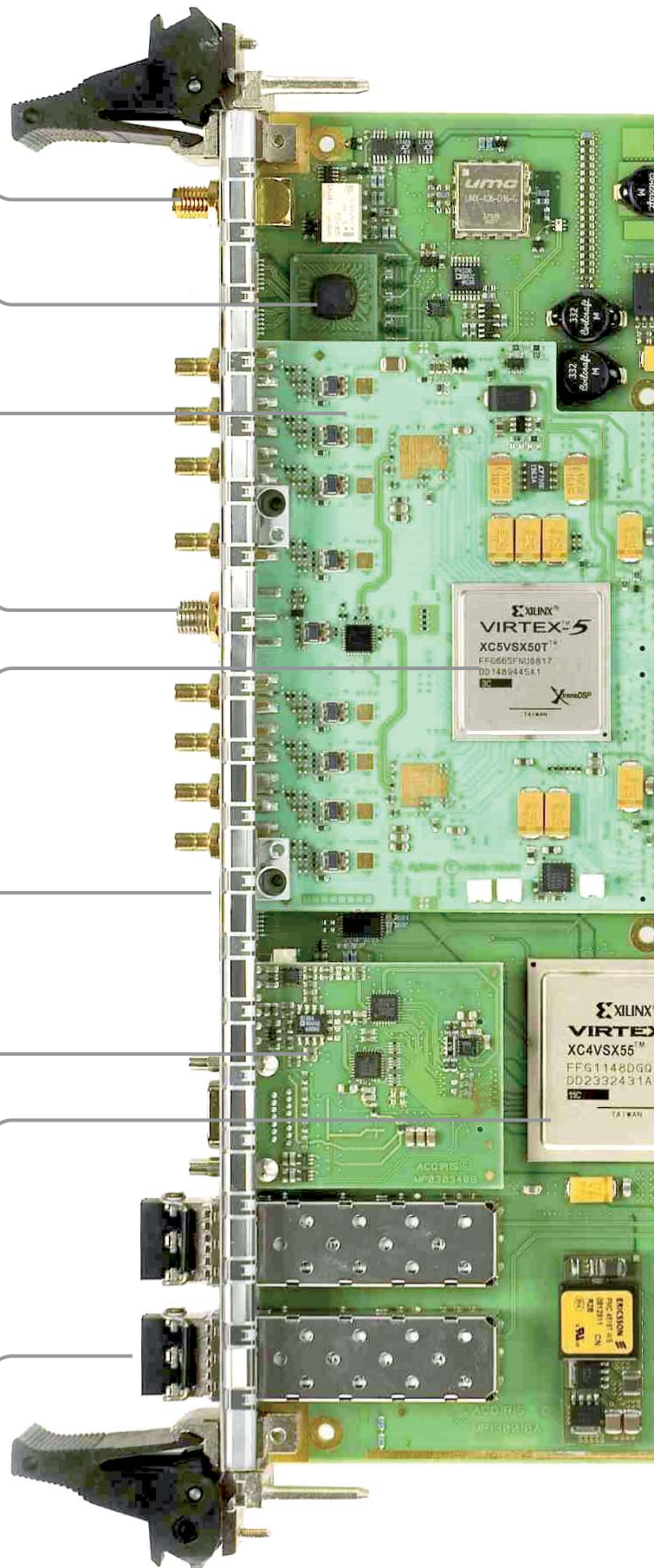

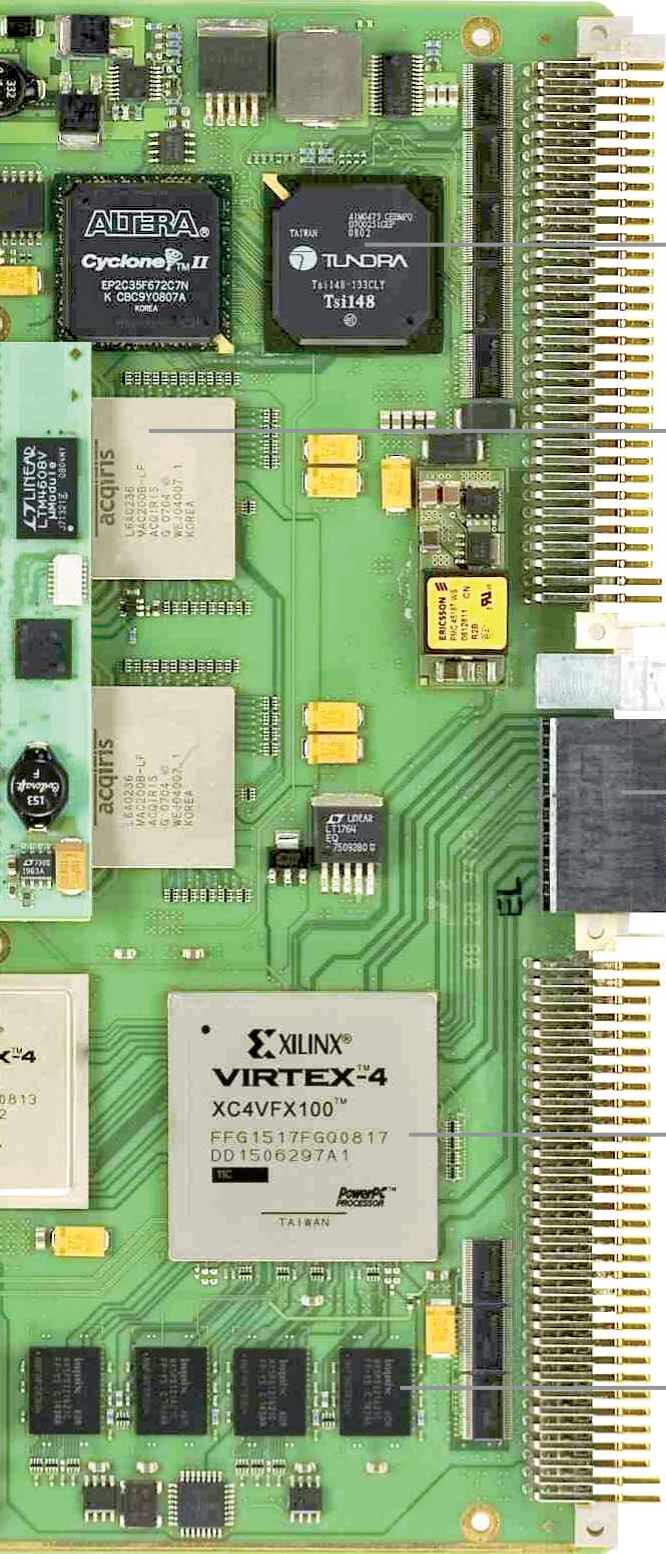

VME 2eSST interface

The SVM4800 is fully VME64x and 2eSST compliant. Designed to benefit from fast data interfaces, it can be integrated with other state-of-the-art VME boards.

Fast data throughput with large memories

The MAC200 memory and acquisition controller is a digital CMOS integrated circuit. A high-speed data multiplexer/demultiplexer with on-board memory, it is designed for the capture and memorization of 10-bit or 20-bit digital data, at speeds of up to 2 GS/s or the generation of 20-bit data streams at up to 1.2 GS/s.

VXS VITA 41 interface

The VXS VITA 41.0 standard gives the SVM4800 the very-high-data-throughput capability needed in EW, Radar, or ATE equipment. The eight serial links available on the P0 connector support up to 3.125 Gbps each, for an aggregate throughput of up to 2.5 GBytes/s. Protocols such as RapidIO, PCI-EXPRESS®, Infiniband, or Gigabit Ethernet, as defined in the VITA 41 dot-standards, can be supported through off-the-shelf FPGA IP cores.

On-board communication controller FPGA

The Xilinx Virtex-4 FX100 FPGA is capable of executing up to 160 multiplications/accumulation (18x18) at up to 450 MHz, leading to an impressive processing power of 70 GigaMAC/s while offering more than 94,000 logic cells and up to 6.7 Mbits of on-chip RAM. Moreover, the FX100 includes two PPC cores and four 10/100/1000 Ethernet MAC blocks. The on-board FPGA-based Signal Processing Unit allows the platforms to be easily reconfigured to perform user-defined, on-board, realtime signal processing

Large memory

The Xilinx Virtex-4 FX100 interfaces to two banks of DDR2-533 SDRAM, 32 MWords, each 64-bit wide, for a total of 512 MB.

Figure 2 : Agilent SVM4800 eight-channel digitizer.

Data-Flow-Optimized Architecture

The VME/VXS board family has been designed to optimize both internal and external data throughput.

Associated with other members of the family, the SVM4800 allows the construction of complete systems with fewer resources.

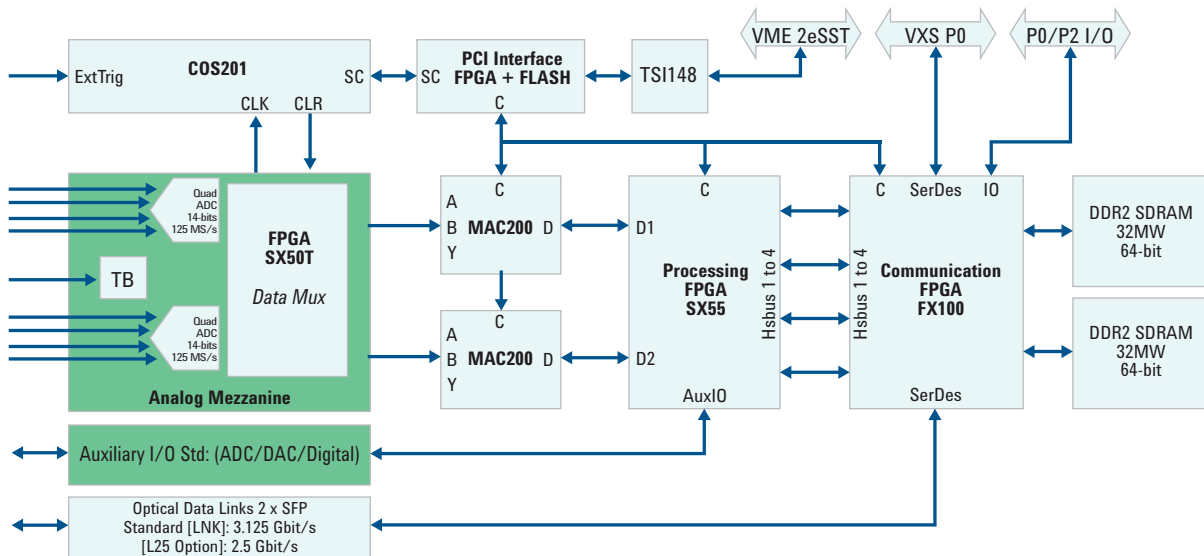

Figure 3 : SVM4800 architecture.

High-Resolution, High-Sample-Rate Data Acquisition Mezzanine

The SVM4800 digitizer's analog mezzanine implements two 14-bit, 125 MS/s Texas Instruments ADS6445 ADCs. Each eight analog input channels are DC-coupled and have a full scale range of 8 V. The module works in external clock only, which allows using best external generators to optimize

analog performance. The analog mezzanine also includes a Xilinx Virtex-5 SX50T FPGA implemented as digital data multiplexer able to correct static offset and gain errors.

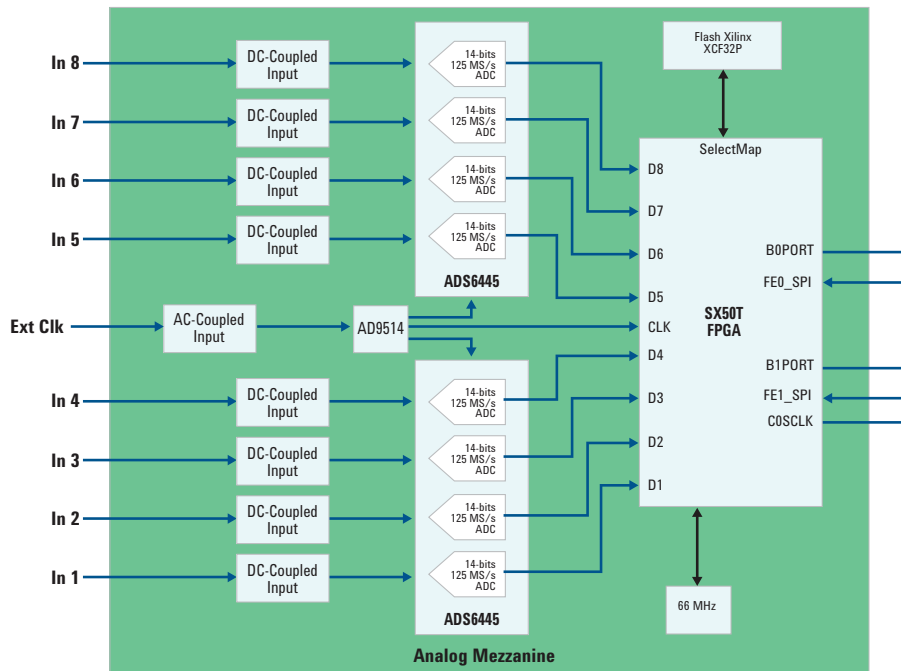

Figure 4 : Analog mezzanine architecture.

Easy Custom Application Development

Firmware development kit

The U1083A board family is available with an optional Firmware Development Kit (FDK) to make application development easier on the SX55 and FX100 FPGAs. The FDK includes a set of cores to easily interface to the underlying hardware, a base design for each family member to provide very simple, ready-to-use designs, and a test-bench environment for design and simulation.

An embedded FLASH memory can store up to seven bit-streams for each FPGA for complex, multimode applications.

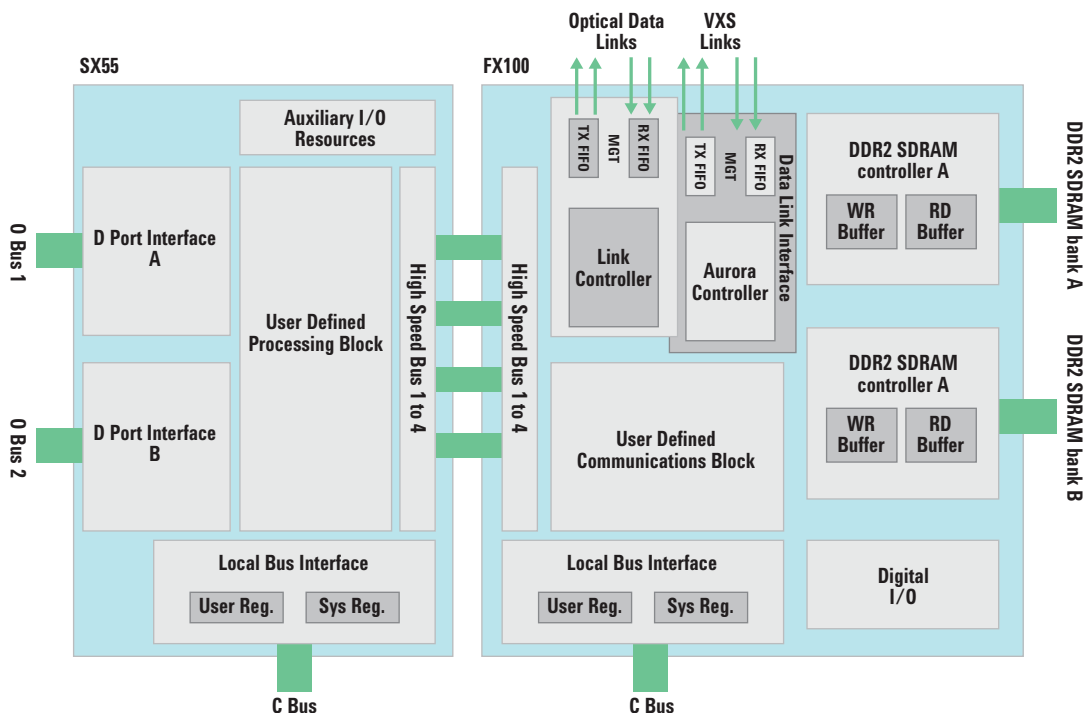

Figure 5 : Firmware development kit architecture.

MicroDriver Software

The SVM4800, is supplied with MicroDriver, a C standard compliant software driver. It runs on standard operating systems, as well as on Real-Time operating systems: MicroDriver supports VxWorks (Pentium® and PowerPC), Linux (Pentium and PowerPC), and Windows® (Pentium).

MicroDriver is provided as full source code and gives direct access to the module registers, as well as main components, including FLASH and DDR2 memories, FPGAs, and back-plane and front-panel links. MicroDriver works in conjunction with the PCI to VME bridge device driver of the host to provide VME burst transfers (including 2eSST) and interrupts.

MicroDriver has been specially designed for the U1083A family products so that every single line of code is useful, implying a very low footprint driver, that can even be reduced further to include only the needed SVM4800 module functionalities.

High-Fidelity Frequency-Related Measurements

Agilent Acqiris Data Converter group long-standing know-how in digitizers' development, coupled with advanced technologies, allow reaching high-fidelity measurements.

Innovative design, careful circuit layout and custom ICs are all used to optimize analog performance.

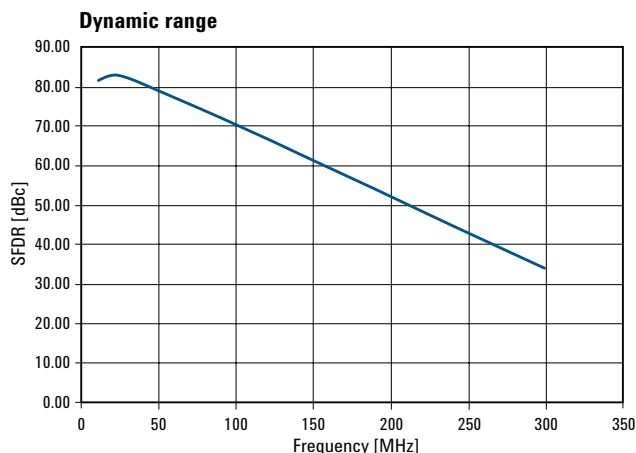

Figure 6 : Typical Spurious Free Dynamic Range (SFDR) as a function of frequency for an acquisition running at 125 MS/s sampling rate and with an input signal amplitude of -1 dBFS.

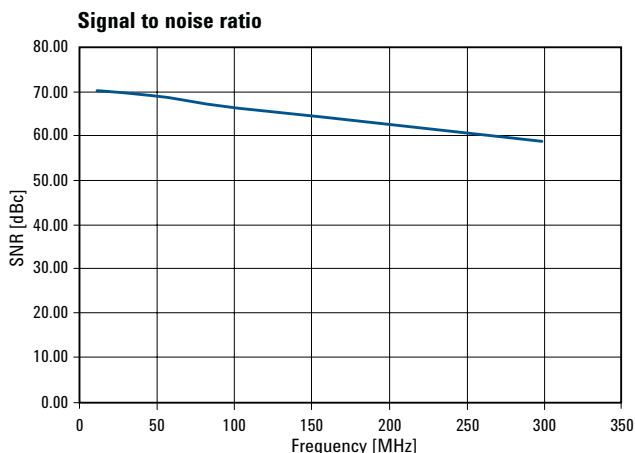

Figure 8 : Typical Signal to Noise Ratio (SNR) as a function of frequency for an acquisition running at 125 MS/s sampling rate and with an input signal amplitude of -1 dBFS.

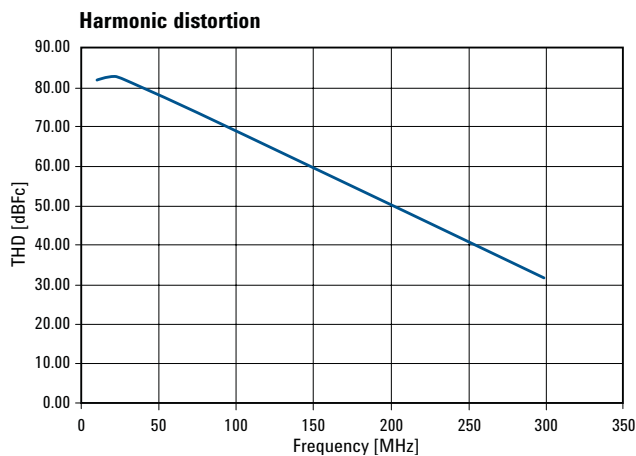

Figure 7 : Typical Total Harmonic Distortion (THD) as a function of frequency for an acquisition running at 125 MS/s sampling rate and with an input signal amplitude of -1 dBFS.

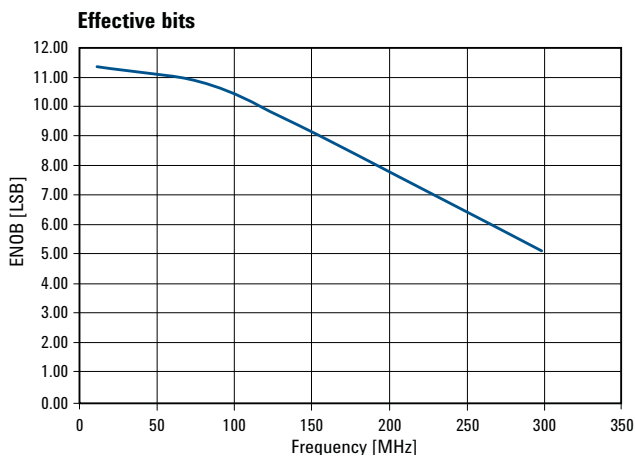

Figure 9 : Typical Effective Number Of Bits (ENOB) as a function of frequency for an acquisition running at 125 MS/s sampling rate and with an input signal amplitude of -1 dBFS.

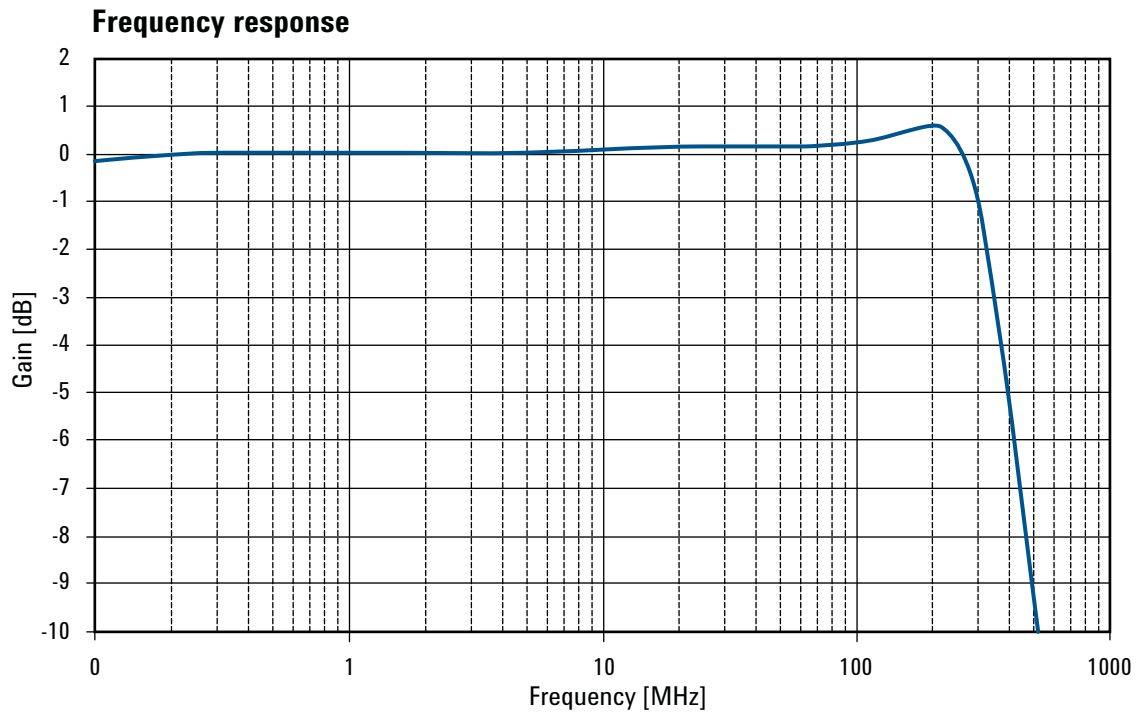

Figure 10 : Typical analog input bandwidth.

Acqiris High-Speed VME/VXS Data Converters

Model SVM4800

Eight-channel, 14-bit, 125 MS/s digitizer

Signal input

Bandwidth (-3 dB)
>300 MHz

Input voltage
 ± 4 V DC (22 dBm)

Coupling
DC

Impedance
 $75 \Omega \pm 2\%$ at DC

Connectors
SMB, gold-plated

Digital conversion

Sample rate
External clock only:
10 MHz to 125 MHz

Channels
Eight

Resolution
14 bits (1:16384)

System performance

Sampling rate: 125 MS/s
Input signal amplitude: -1 dBFS
Input signal frequency: 50 MHz

SFDR (typ.)
>79 dBc

THD (typ.)
>78 dB

SNR (typ.)
>68 dBc

ENOB (typ.)
>11

External clock input

Input amplitude
> 2 V pk-pk into 50Ω (10 dBm)

Maximum input voltage
3 V pk-pk into 50Ω (13 dBm)

Ext. clock frequency
from 40 MHz to 125 MHz

Connector
SMA, nickel-plated

Time base

Acquisition modes
Continuous / software triggered

Trigger (external)

Sensitivity
Sensitivity > 5% Full Scale
DC to 1 GHz at 50Ω
DC to 300 MHz at $1 M\Omega$

Impedance
 $50 \Omega \pm 1\%$, $1 M\Omega$ at DC

Connector
SMA, gold-plated

Full scale
 ± 5 V

Modes
Edge, positive and negative

Auxiliary I/O

Digital signals
14 I/O configurable as 7 LVDS pairs
 μ DB15 connector

One digital I/O LVTTTL 3.3V,
5V tolerant, MMCX,
gold-plated connector (I/O P1)

Analog input
12-bit 65 MS/s ADC
 ± 1 V DC 50Ω input
MMCX, gold-plated connector

Analog output
12-bit 130 MS/s DAC
 ± 1 V DC into 50Ω
MMCX, gold-plated connector

On board memory

FLASH
128 MB

SDRAM
2 x 256 MB DDR2 533

Optical data links

Transceiver
2 x Small Form Pluggable
Multimode 850 nm

Connector
LC Duplex

Throughput
3.125 Gbps/link
Option 2.5 Gbps/link

Host interface

VME

Full VME64x and 2eSST compliance

VXS

8 x serial links on P0
3.125 Gbps/link
Aggregate: up to 25 Gbps
Option 2.5 Gbps/link

Digital IO

12 LVDS pairs on P0
20 LVDS pairs on P2
One SPI interface on P2

Supported host and OS¹

Single board computers

Kontron :
PowerNode3, PowerEngine
(Linux, VxWorks)
PentXM, PentXM2 (Linux)

Concurrent Technologies:
VP337 (Linux)
VP426 (WinXP)

GE Fanuc:
V7812 (WinXP)

Interfaces

GE Fanuc Bus Adapter 810 (WinXP)

General and physical

Power consumption

< 80 W typ.

Dimensions

6U VME standard
233.35 mm x 160 mm x 20.02 mm

Front panel complies with IEEE1101.10

CE Certification and Compliance

Current requirements (typ.)²

+12 V	0.4 A
+5 V	6.4 A
+3.3 V	9.2 A
-12 V	0.2 A

EMC

Complies with European EMC
directive 2004/108/EC
- IEC/EN 61326-2-1
- CISPR Pub 11 Group 1, class A
- AS/NZS CISPR 11
- ICES/NMB-001

This ISM device complies with
Canadian ICES-001.
Cet appareil ISM est conforme à la
norme NMB-001 du Canada.

Warranty

1 year

Environmental³

Operating temperature

0° to 60°C

Non operating temperature

-40° to 85°C

Required airflow

>2 m/s at sea level

Altitude

-1,000 to 15,000 ft

Shock/Vibration

- Operating random vibration - type
tested at 5 to 2000 Hz, 7.6 g RMS
(VITA 47 Class V2)
- Survival random vibration - type
tested at 5 to 500 Hz, 2.09 g RMS
- Functional shock - type tested,
halfsine, 30 g, 11 ms

Humidity

Relative Humidity type-tested at
95%, +40°C (non-condensing)

1) For other configurations, please contact factory.

2) SVM4800 sampling at 125 MS/s, FPGA with base
design. Depending on FPGA customer usage.

3) Samples of this product have been type tested
in accordance with the Agilent Environmental Test
Manual and verified to be robust against the envi-
ronmental stresses of Storage, Transportation and
End-use; those stresses include but are not limited to
temperature, humidity, shock, vibration, altitude and
power line conditions. Test Methods are aligned with
IEC 60068-2 and levels are similar to MIL-PRF-28800F
Class 3.



Contacts

Americas

Canada	(877) 894-4414
Latin America	305 269 7500
United States	(800) 829-4444

Asia Pacific

Australia	1 800 629 485
China	800 810 0189
Hong Kong	800 938 693
India	1 800 112 929
Japan	0120 (421) 345
Korea	080 769 0800
Malaysia	1 800 888 848
Singapore	1 800 375 8100
Taiwan	0800 047 866
Thailand	1 800 226 008

Europe & Middle East

Austria	43 (0) 1 360 277 1571
Belgium	32 (0) 2 404 93 40
Denmark	45 70 13 15 15
Finland	358 (0) 10 855 2100
France	0825 010 700*
	*0.125 €/minute
Germany	49 (0) 7031 464 6333
Ireland	1890 924 204
Israel	972-3-9288-504/544
Italy	39 02 92 60 8484
Netherlands	31 (0) 20 547 2111
Spain	34 (91) 631 3300
Sweden	0200-88 22 55
Switzerland	0800 80 53 53
United Kingdom	44 (0) 118 9276201
Other European Countries:	www.agilent.com/find/contactus

Revised: October 1, 2009

Ordering Information

Model	Description
U1083A-007	Eight-channel, 14-bit 125 MS/s SVM4800 digitizer module
U1083A-FDK	Firmware development kit for VME-VXS platform
Options	
U1083A-LNK	Standard data link
U1083A-L25	2.5 Gbps VXS and front panel links
Accessories	
U1092A-CB1	MMCX to BNC, 1 m cable
U1091A-CB1	Chipscope cable and connector

For more information on Acqiris product line, sales or services, see our website at:

www.agilent.com/find/acqiris

For more information on Agilent, go to:

www.agilent.com

Windows is a U.S. registered trademark of Microsoft Corporation.

Pentium is a U.S. registered trademark of Intel Corporation.

PCI Express and PCIe are registered trademarks of PCI-SIG.

Product specifications and descriptions in this document subject to change without notice.

© Agilent Technologies, Inc. 2009
 Printed in USA, November 10, 2009
 5990-4152EN



Agilent Technologies